

Dimensions of PN 160 flanges

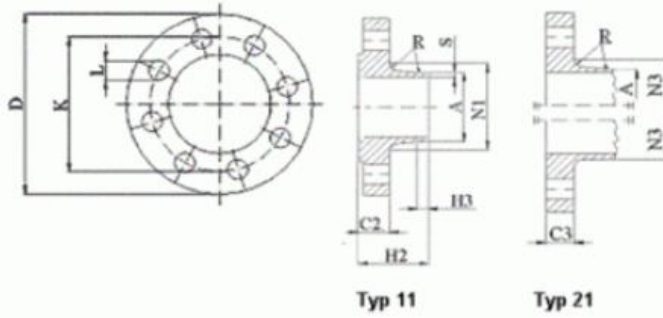

Flanges acc. to EN 1092-1



Nominal diameter DN	Mating Dimension					Outside diameter of neck	Flange thickness		Length		Neck diameter		Corner Radius		Neck thickness (Preferred value)	
	Outside diameter	Diameter of bolt circle	Diameter of bolt holes	Bolting			C2	C3	H2	H3	N1	N3	R1			S
	D	K	L	No.	size		A									
DN	Flange type (typ)															
	11,21					11 21*	11	21	11	11	11	21	11	21	11	
10	100	70	14	4	M12	17,2	20	20	45	6	32	40	4	4	2	
15	105	75	14	4	M12	21,3	20	20	45	6	34	45	4	4	2	
25	140	100	18	4	M16	33,7	24	24	58	8	52	61	4	4	2,9	
40	170	125	22	4	M20	48,3	28	28	64	10	70	82	6	4	3,6	
50	195	145	26	4	M24	60,3	30	30	75	10	90	96	6	4	4	
65	220	170	26	8	M24	76,1	34	34	82	12	108	118	6	5	5	
80	230	180	26	8	M24	88,9	36	36	86	12	120	128	8	5	6,3	
100	265	210	30	8	M27	114,3	40	40	100	12	150	150	8	5	8,0	
125	315	250	33	8	M30	139,7	44	44	115	14	180	184	8	6	10	
150	355	290	33	12	M30	168,3	50	50	128	14	210	224	10	6	12,5	
200	430	360	36	12	M33	219,1	60	60	140	16	278	288	10	8	16	
250	515	430	42	12	M39	273,0	68	68	155	18	340	346	12	8	20	
300	585	500	42	16	M39	323,9	78	78	175	18	400	414	12	10	22,2	